



Introduction to H.323

Jim Toga, Director - Engineering
jim.toga@edial.com

Real-time multimedia communications and conferencing for packet-based networks

What Can You *Do* With H.323?

- Multimedia communications (audio, video, fax data) on packet-based networks
- Build a heterogeneous network to bridge to other multimedia networks (H.320, H.324, H.310, POTS...)
- Point-to-Point, Multipoint

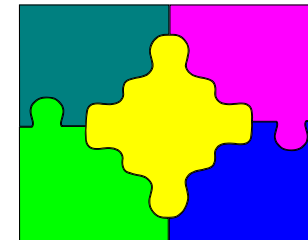
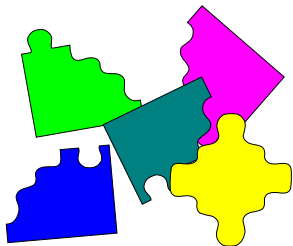

In the Beginning...

- Initial vision to define H-Series standard for Local Area Networks
 - ‘Local Area Networks & Non-Guaranteed QoS’
 - Now - ‘Packet Based Multimedia’
- Tightly controlled conference model
- Outgrowth of other ‘standards’ building blocks
- Initial ‘framework’ of facilities
 - peer-peer or ‘cloud’ model
 - functional points of control

Standards Food Chain

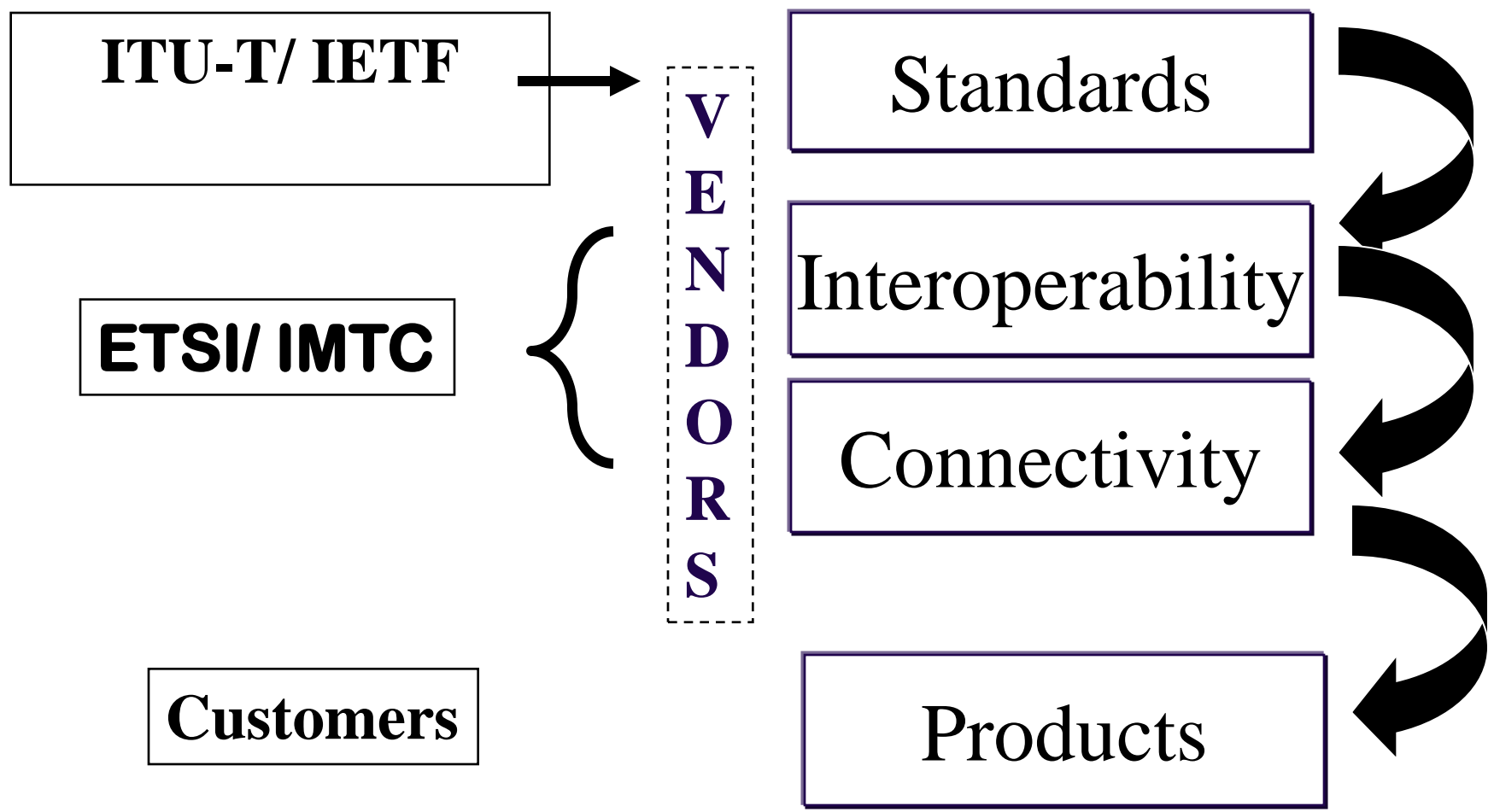

The H.323 'Players'...

- Terminal (what people see/hear)
- GK - gatekeeper (control and 'routing')
- GW - gateway (access to other environments)
- MC - multipoint controller ('crowd' control for the masses)
- MP - multipoint processor (mix 'n match the media)
- MCU - multipoint control unit (big 'iron')
 - contains MC and MP optionally a T.120 MCU

Endpoints

- Terminal – device used by the actual end user (e.g., packet telephone or PC with a microphone, speakers, *camera*)
- Gateway – converts between an H.323 “network” and some other network (e.g., voice gateway that connects to the ISDN)
- MCU – provides conference capabilities among H.323 endpoints

Other elements...

- **Gatekeeper** –provides application-level admission and address translation. Can also perform additional functions, such as call processing or access to databases for routing services (e.g., TCAP).
- **MC** - controller for multipoint conferences
- **MP** - media processor (e.g., audio mixer)

Gatekeepers

- Necessary for operation - but not *mandatory* in H.323
 - Endpoints must interact with Gatekeeper if present
- “Required” with Gateways
 - address resolution
- Minimal set of functions required
 - Address translation and/or redirection
 - Call admission/authorization
- Some (coarse) bandwidth management
 - Centralized point for resource reservation

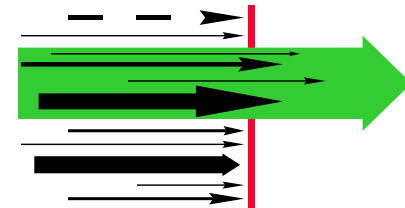
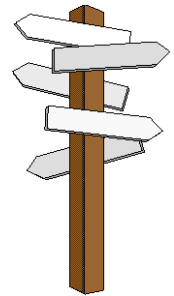

Gateways

- Provide interoperability between different telecommunications systems
- Gateways are logically two endpoints, one in each telecom domain
- Encoding, protocol, and call control mappings occur in the gateways between the two endpoints
- H.323 Proxy: a special “null” gateway, with two H.323 endpoints

Gateway as H.323 Endpoint

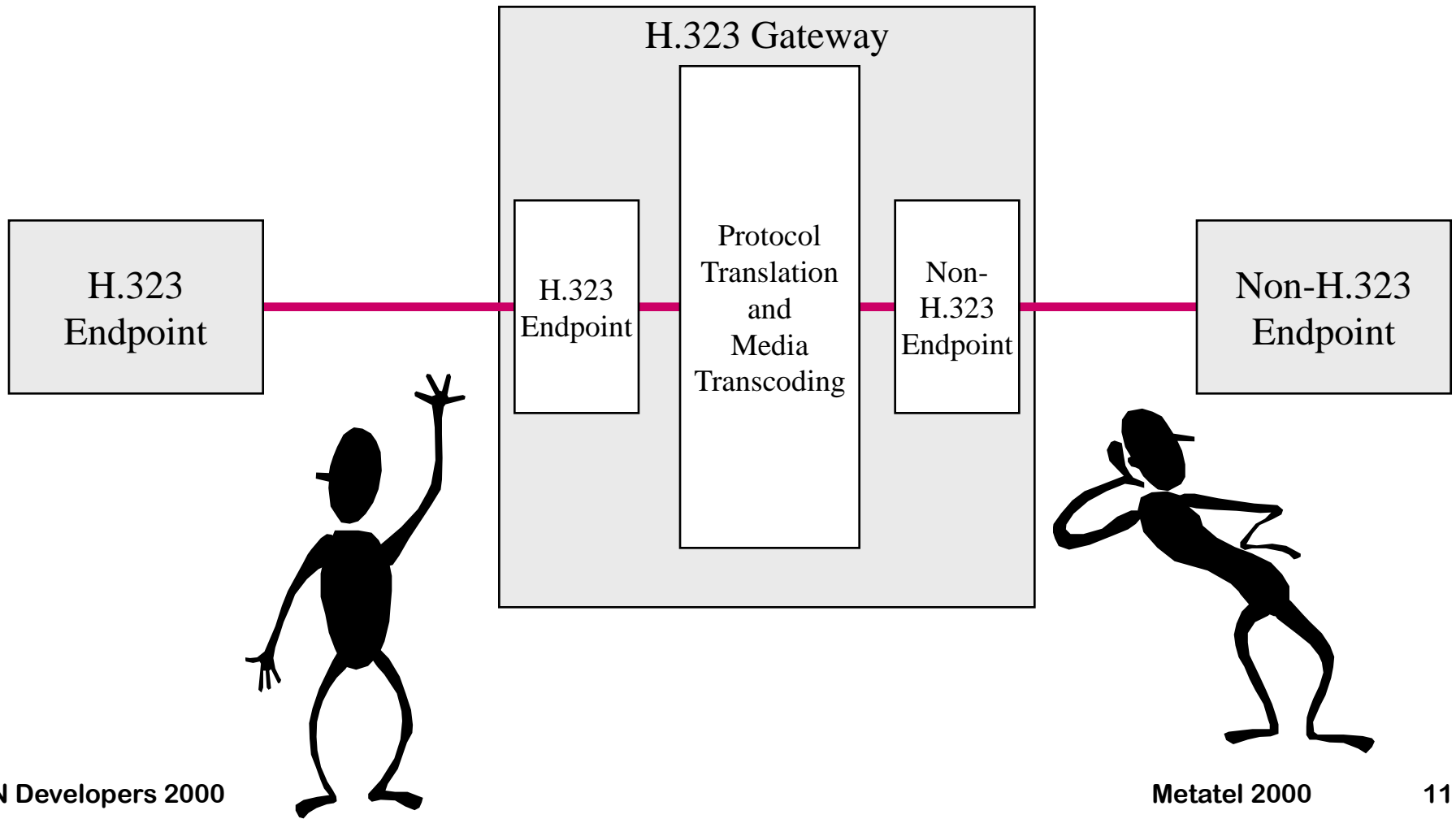

Multipoint Control Unit (MCU)

- **Manages conference using H.245 and may use T.120 commands**
- **Establishes common conference mode**
 - Common set of media streams
 - May provide audio transcoding
- **Distributes multicast addresses if utilized**
- **Two media exchange types**
 - Centralized (centralizedAudio, centralizedVideo)
 - Decentralized (decentralizedAudio, decentralizedVideo)

H.323 Proxies

- Breaks an H.323 session into two distinct call legs
- Can be an element of a firewall
- Capable of hiding interior addressing information from the outside world

Basic Operation

- Endpoints register with gatekeeper to provide mapping between physical address and alias address
- Endpoint asks gatekeeper for permission to place call to another endpoint
- Endpoint signals call with other endpoint
- Endpoints exchange media
- Endpoints disconnect, notify gatekeeper

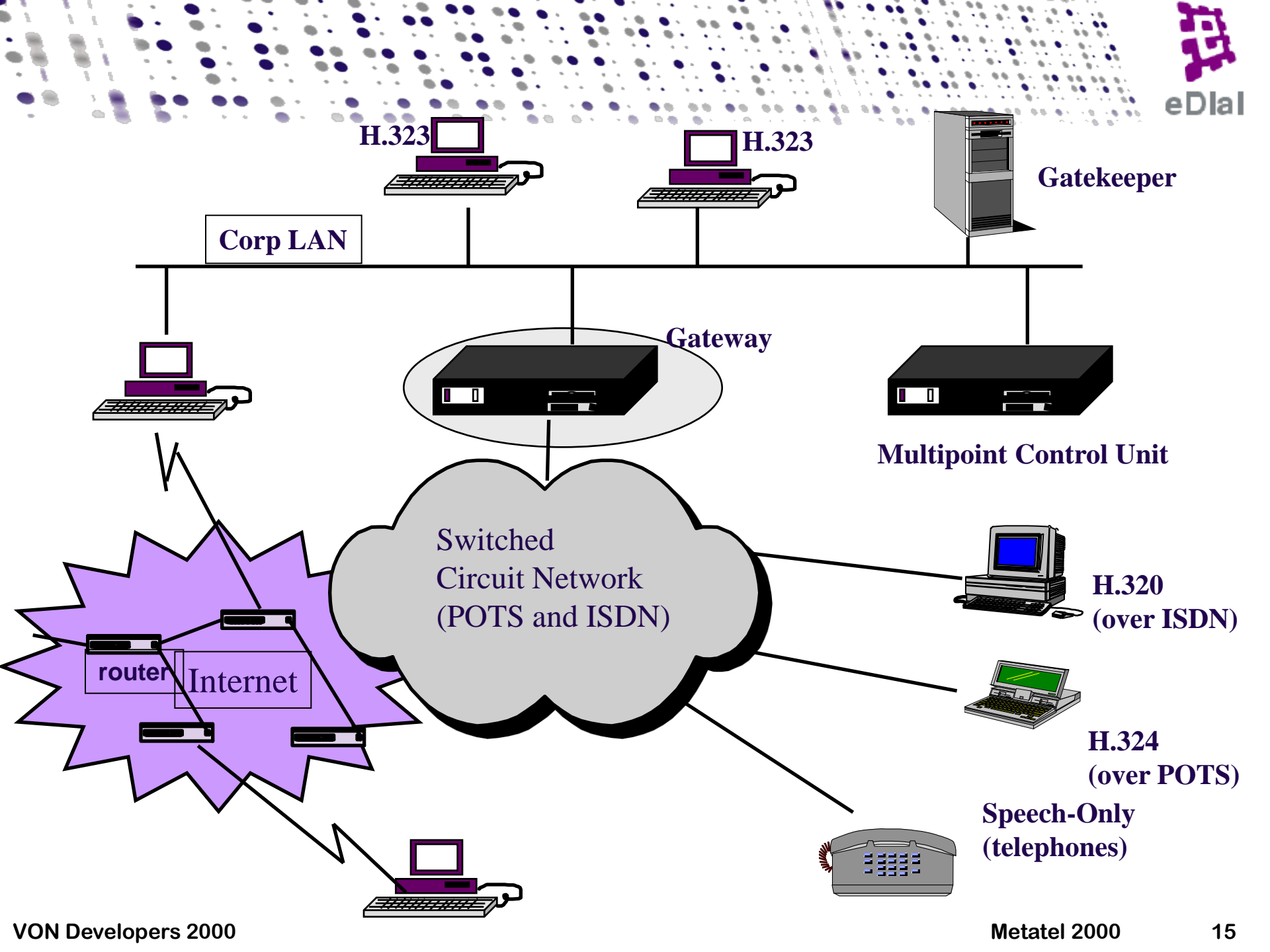

All it is... messages & procedures

- “Admissions” & “Directory Service”
- Creation of a connection (“physical” link)
- Endpoint capabilities exchange
- Opening and closing logical channels
- Changing modes (point-to-point - multipoint)
- Real-time transmission over packet networks

Protocols by the Numbers

- H.323 for architecture, procedures
- H.225.0 more than just a document...
 - Q.931 'derived' messages for call setup
 - RAS for endpoint-Gatekeeper signaling
- H.245 for capabilities/media control
- RTP/RTCP for media transport
 - Endpoint to endpoint after call setup
 - Open multiple logical channels (one per one way media)
- T.120 for data

Protocol 'Pipes'

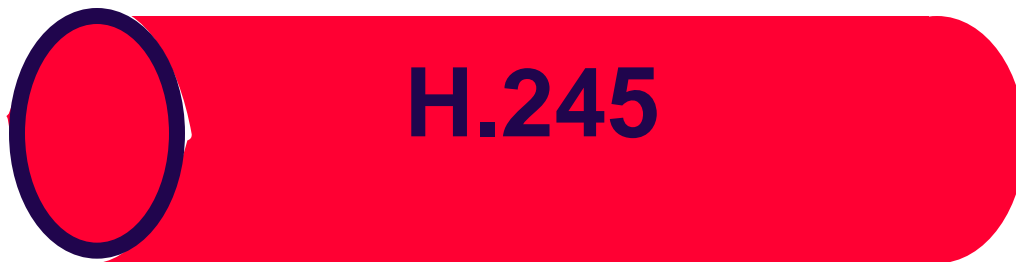

RAS Functions

- **Discovery/Registration** - find gatekeeper and provide mapping between physical and alias addresses
- **Admission** - ask permission to place call with bandwidth
- **Bandwidth Changes** - ask permission to use more bandwidth
- **Status** - report on call status
- **Disengage** - report disconnect and release bandwidth

H.225/Q.931

- Q.931-like (but not identical)
- Setup - initiate call from one entity to another
- Alerting - called endpoint is “ringing”
- Connect - called endpoint answered
- Release Complete - disconnect call
- others, including Facility, Information, Progress, Status

H.245

- **Capability negotiation - determine compatible set of media capabilities**
- **Master/slave determination**
- **Logical channel control - indicate desire to start transmission of specified medium**
- **Multipoint conference control & indication - conference rosters, chair control, media indications**
- **Miscellaneous**

Media

- Audio - ITU-approved (e.g., G.711, G.729, G.723.1), other standard (e.g., GSM), and proprietary coders
- Video (H.261, H.263...)
- Data (e.g., T.120 for collaboration)
- Fax (T.38)

H.235: Security Framework

- No 'minimum' mandates (rich support)
- Negotiable Authentication, Encryption, Integrity
- International considerations addressed
- Encompasses all phases of communications
 - authorization, establishment, media exchange
- Reuse/reference existing standards
 - SSL/TLS, X.509 Certificates, D/H, encryption

H.323 System: Protocol Architecture

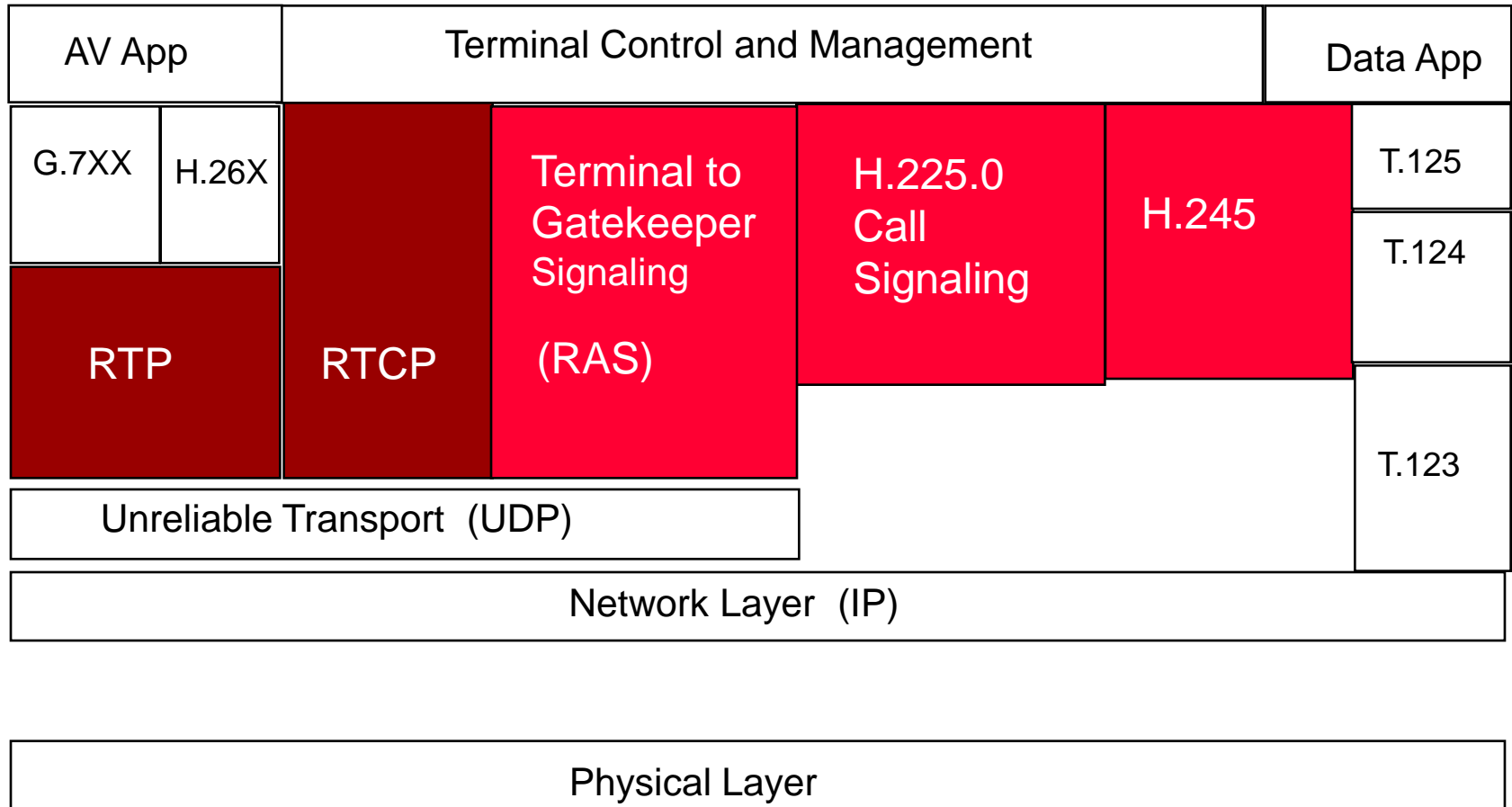

Messages & Procedures

- **Call Setup (call control)**
 - **Permissioning - Gatekeeper (optional)**
 - Provides administrative hook for control
 - Redirection to Gateways or Proxies
 - **Call Establishment (dial and ring the 'phone')**
- **Capability negotiation (H.245)**
- **Multipoint Control (MC)**
 - one chosen 'entity' for conference
 - distribution of multicast addresses

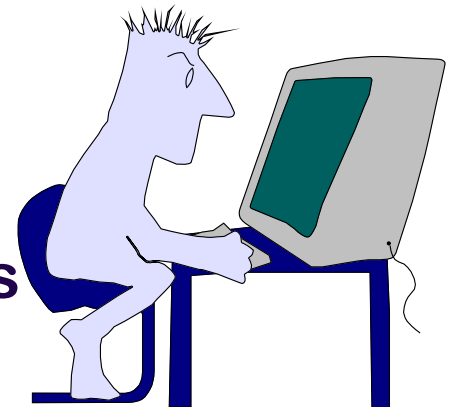

Gatekeeper Zones

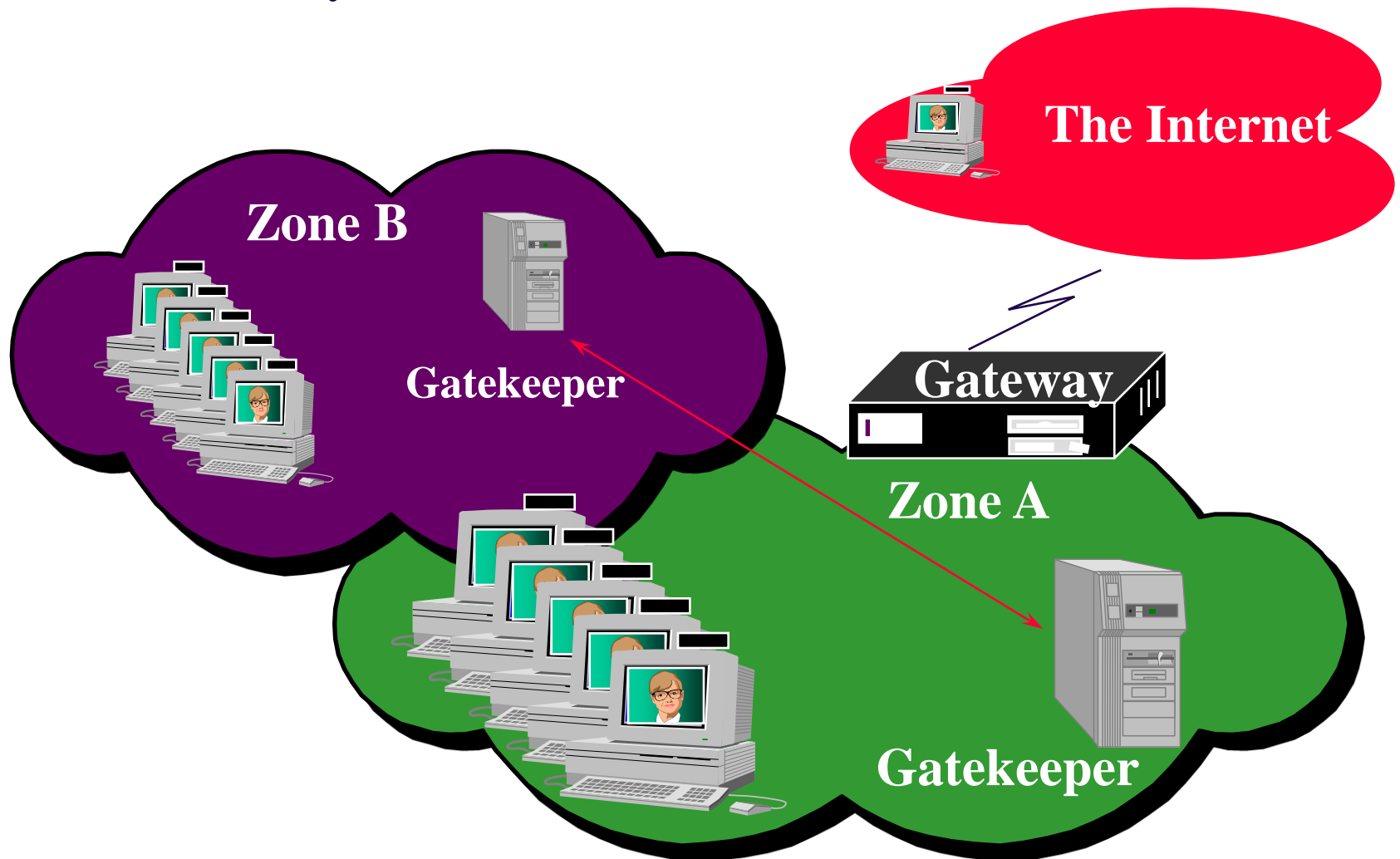

Gatekeeper Zone Characteristics

- Supplies ‘functions’ to a ‘zone’
- Optional features
 - call control/routing (under Gatekeeper control)
 - call management (call status, tracking, PBX-like services etc.)
 - “Hooks” to network administration?
 - Hook for any external policy constraints
 - Hook for any proprietary locally implemented policies
- Implementation issue - involvement with supplementary services

Gatekeeper Zones cont...

- Zone defined by all H.323 devices registered to a single Gatekeeper
- May be independent of physical topology
- Only one active Gatekeeper to a zone
- Zone definition is implementation-specific
- Inter-zone (domain) signaling is maturing

'Traditional' Multipoint (no continuous presence)

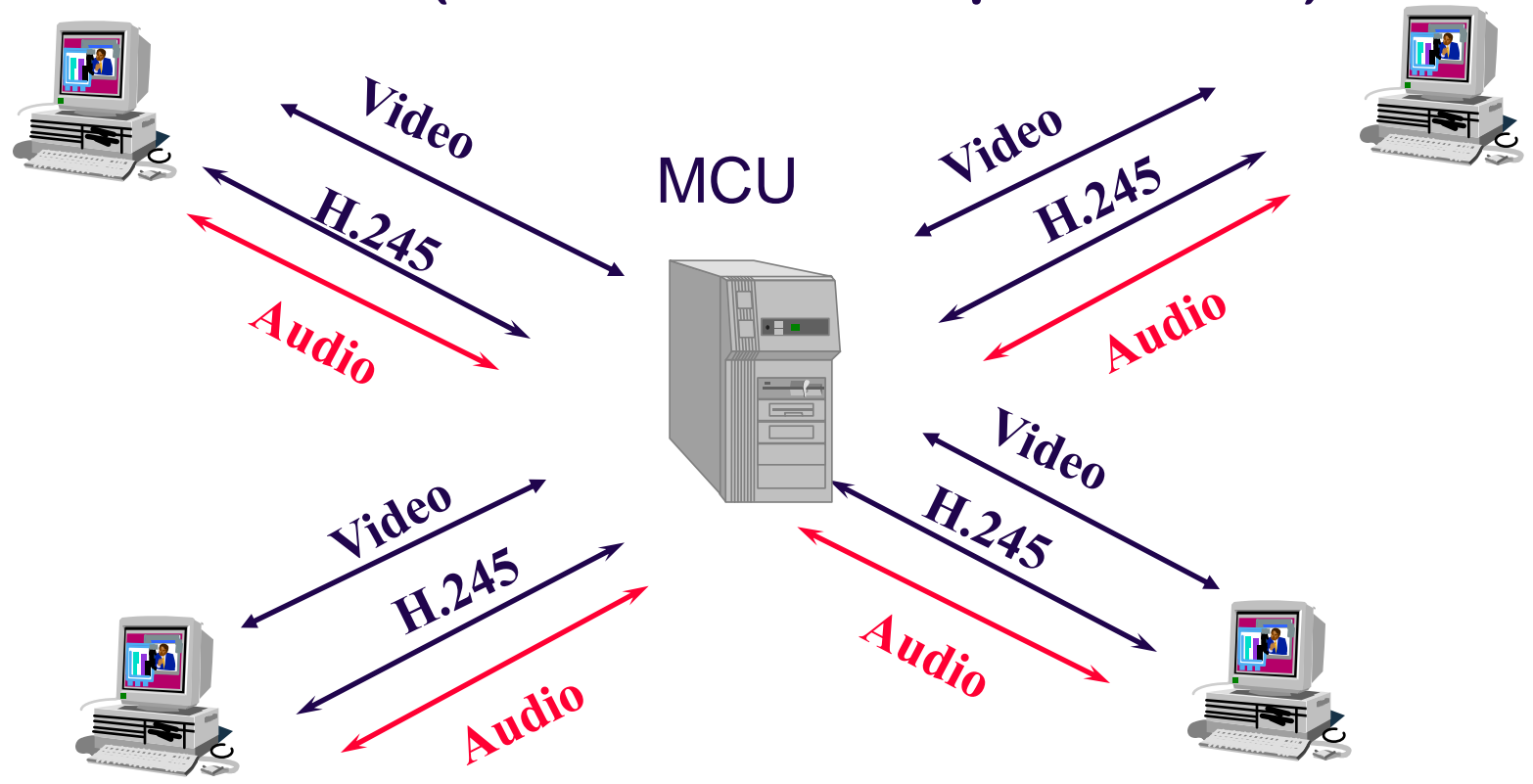

Distributed Multipoint

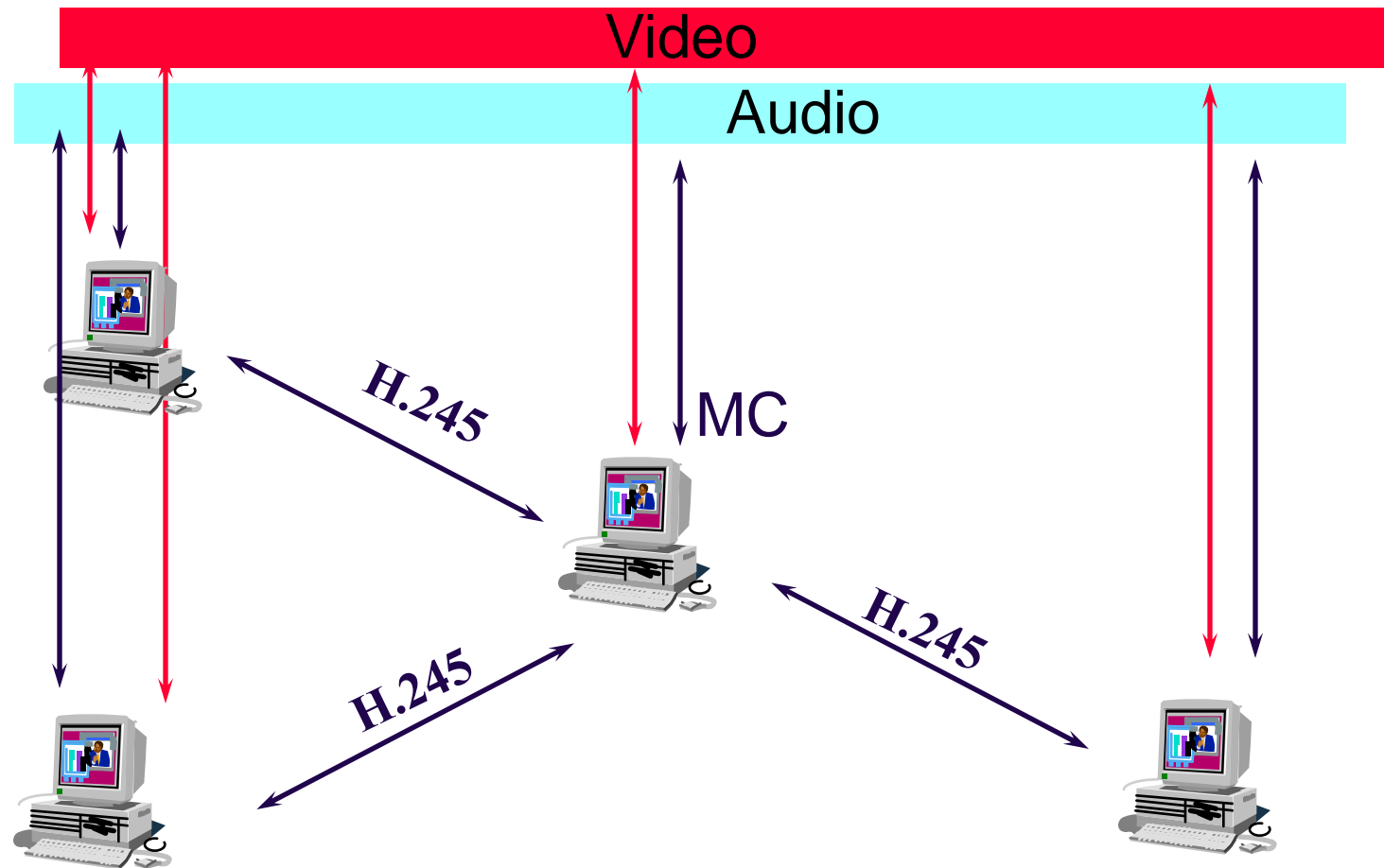

Call Models

- **Direct Endpoint**
 - faster setup
 - endpoints provide features
 - trunk replacement
- **Gatekeeper Routed**
 - Gatekeeper can act as “feature server” or “switch” for call processing features
 - progressive conferencing, other media features

Direct Endpoint Signaling

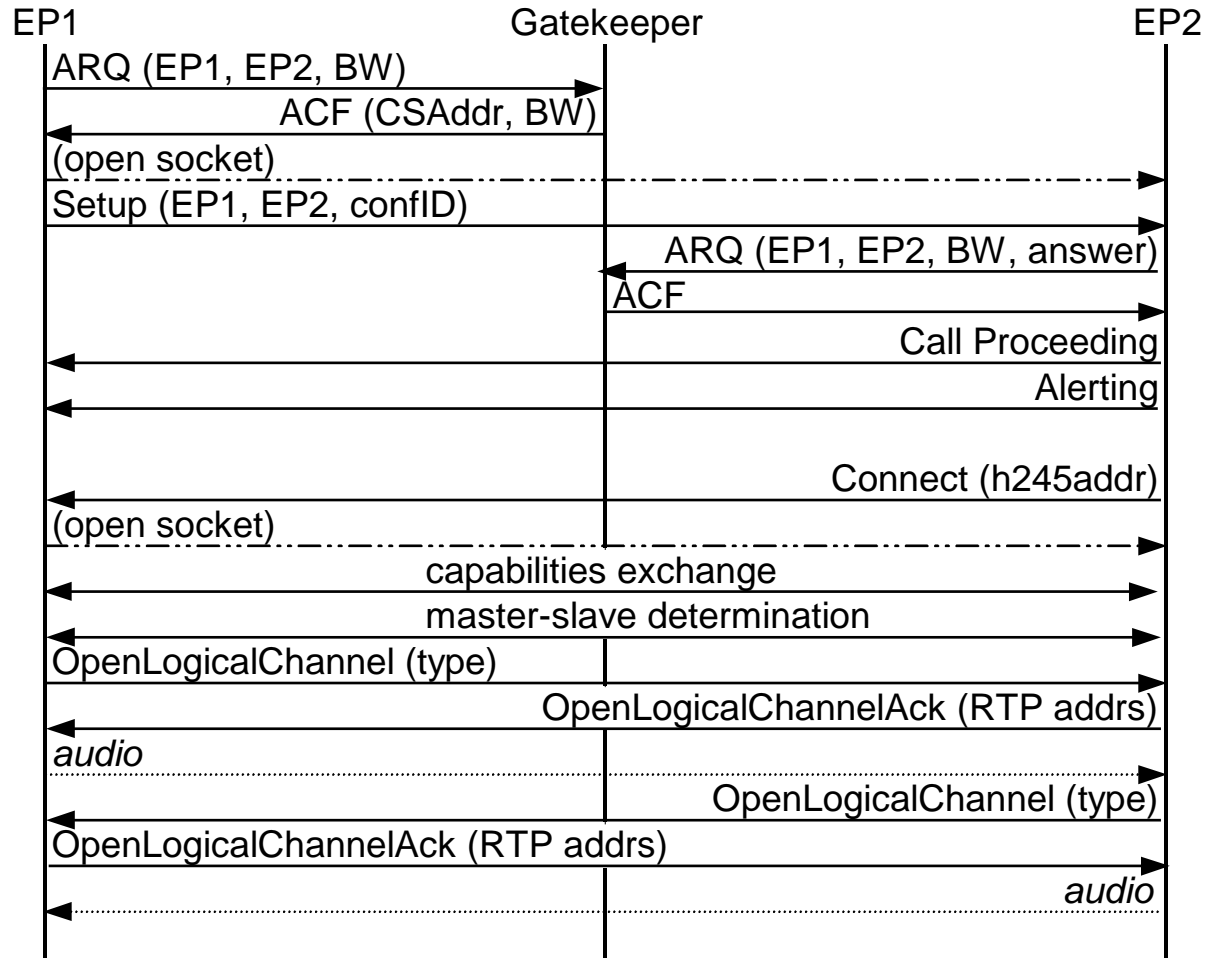

Protocol & Call Setup

Gatekeeper



↔
RAS



H.323
Terminal



H.323
Terminal

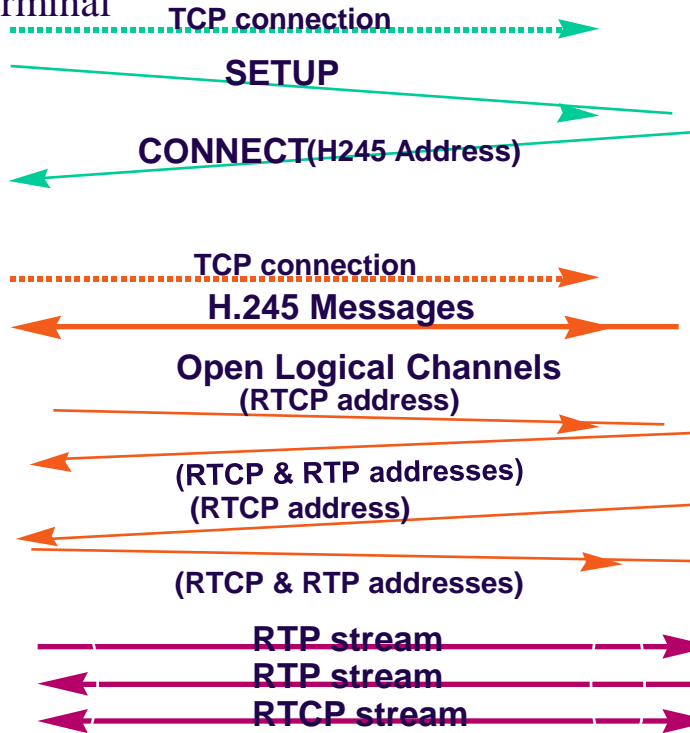

**Q.931
(over TCP)**



**H.245
(over TCP)**



**Media
(over Unicast UDP)**

Gatekeeper Routed Signaling

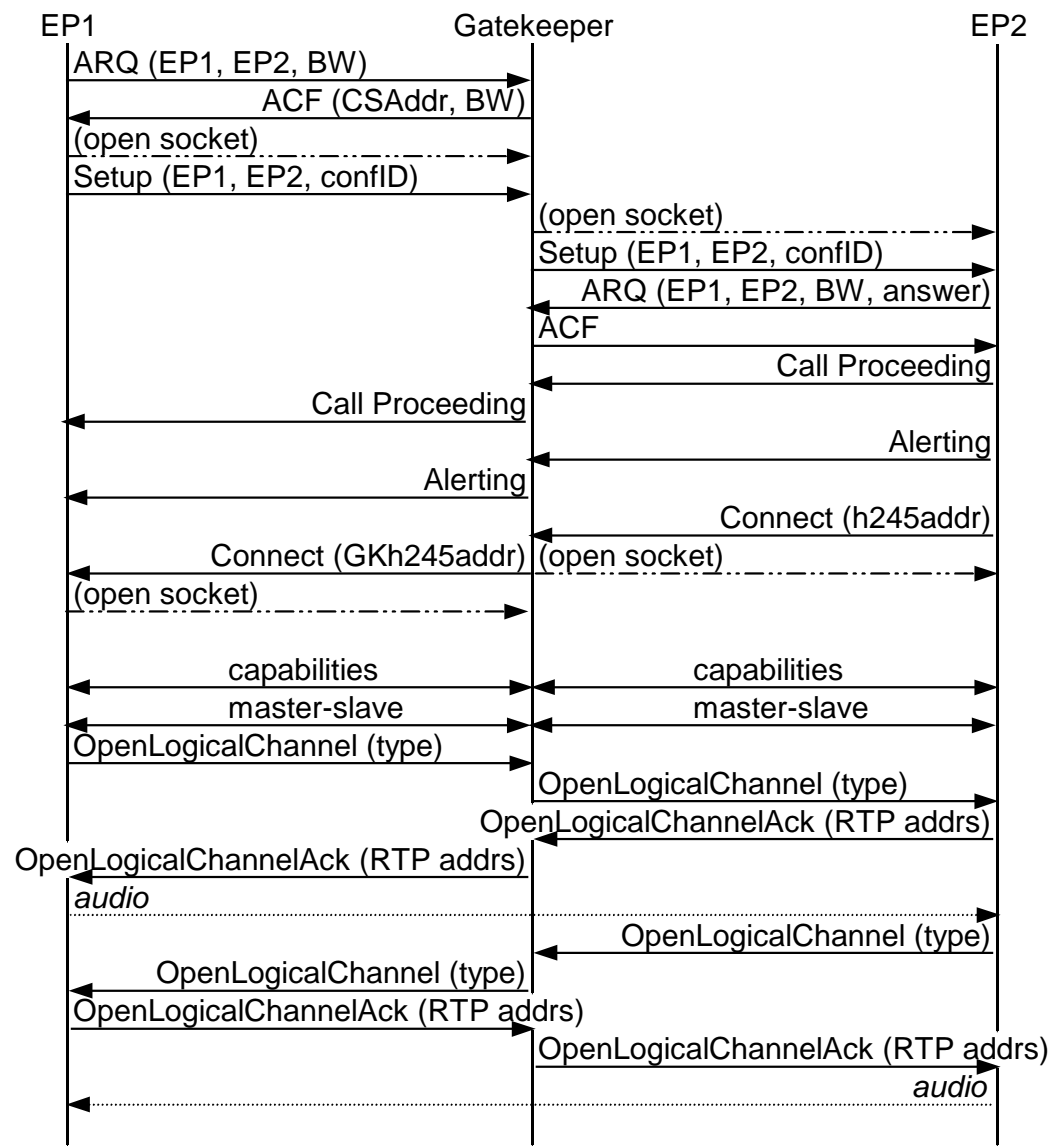

Optimization - Fast Start

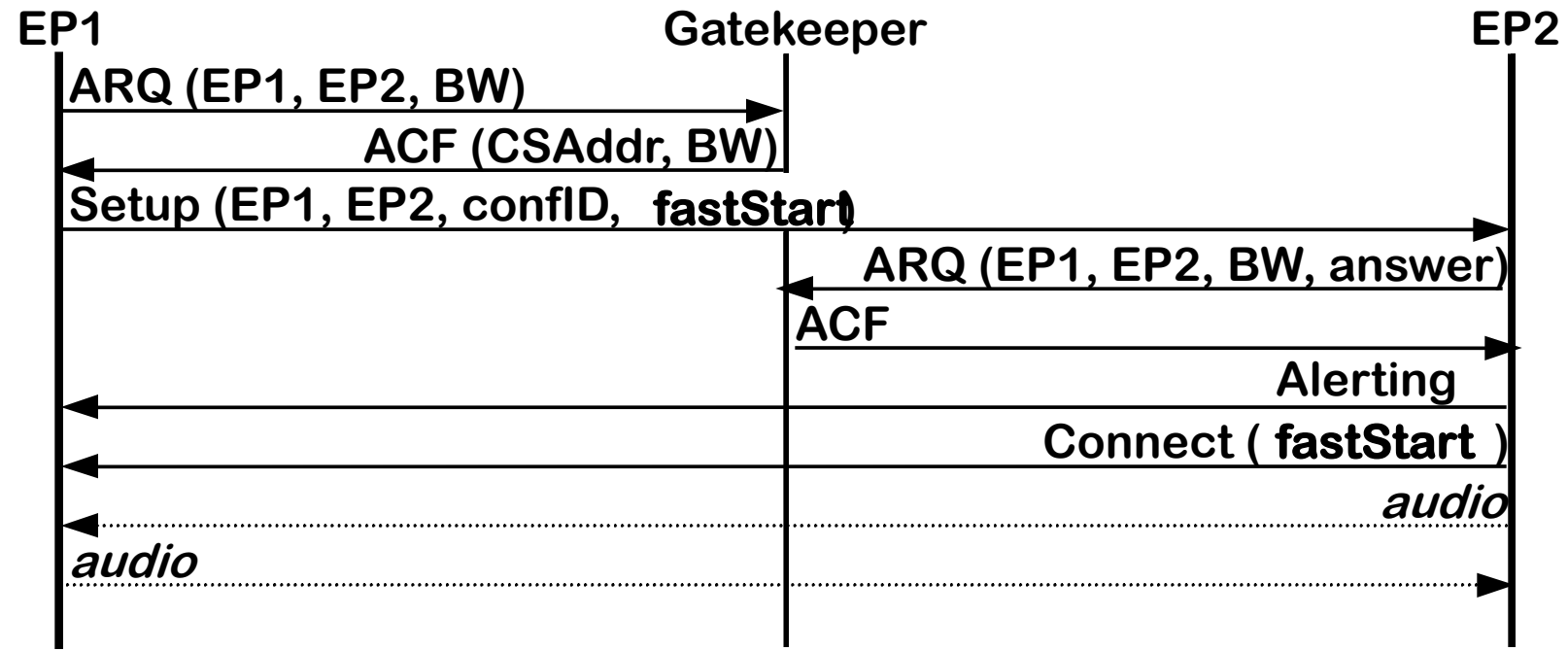

fastStart field contains list of OpenLogicalChannel structures

Fast Start with Early Audio

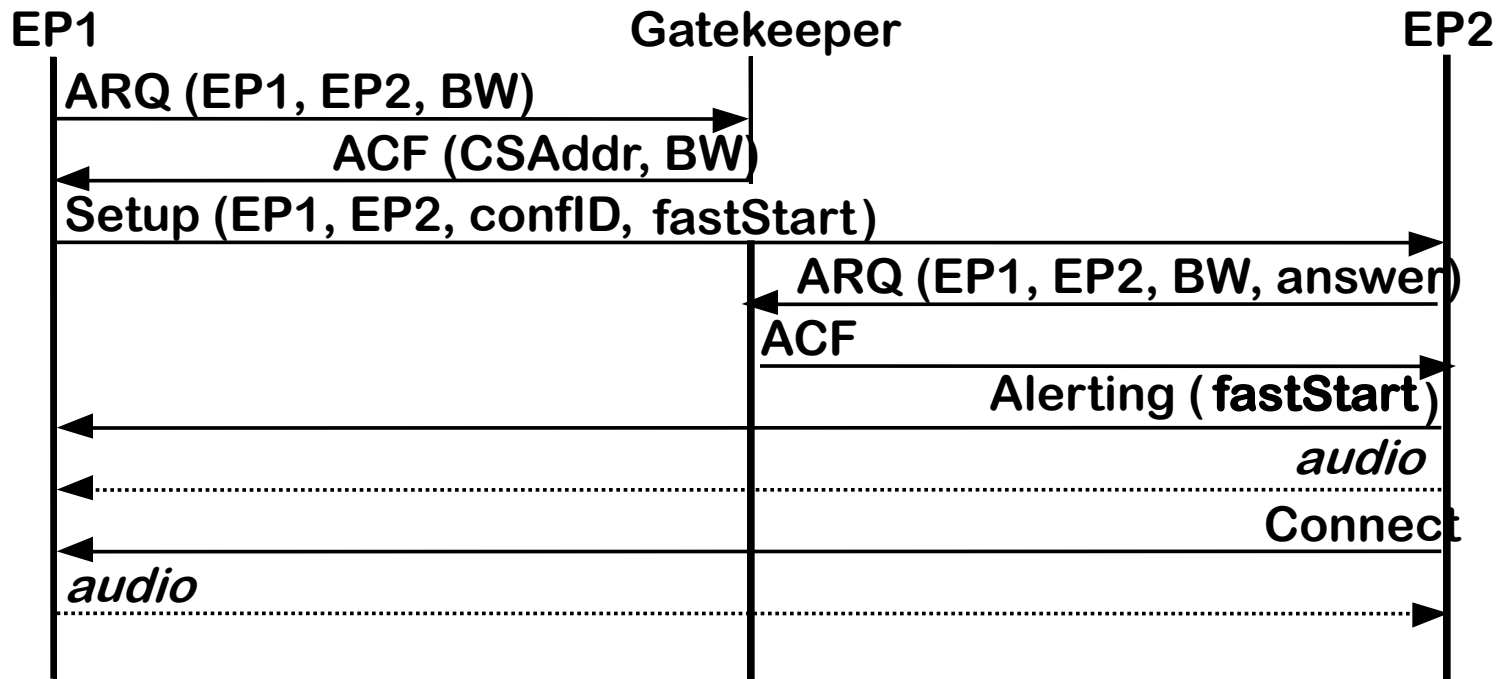

Specialized Optimization Example

- H.323 Annex F defines “Simple Endpoint Type” (SET)
 - first SET type defined for audio only
 - based on fast start, no need for H.245
 - provides encoding guidelines, allowing SET to be built without general ASN.1 codec
 - restricts codec choices

Recommendation Annexes

H.323

- Annex C – H.323 over ATM
- Annex D – H.323 FAX
- Annex E – UDP operation
- Annex F – Simple Endpoints
- Annex J – Security for Simple endpoints
- Annex K – HTTP based call control
- Annex M – Tunneling of QSIG in H.323

H.225.0

- Annex G – Inter-Domain Communications
- Annex H – ASN.1 Syntax

Some Points of Interest

- http://www.imtc.org/act_coip.htm
 - Interops, Profile activities
- <ftp://standard.pictel.com/avc-site/>
 - ITU documents, *good reference*
- www.itu.ch
 - Getting involved in the process, CD Docs

Thank You